

The BA484DF-F Fieldbus Display is an intrinsically safe instrument that can display up to eight fieldbus process variables. Eleven selectable standard screen formats contain one, two, three, four or eight variables, with units of measurement, tag descriptions and bargraphs on some screens.

Selectable function blocks allow the BA484DF-F fieldbus display to be used with all common system hosts. Configuration files may be downloaded from the Fieldbus Foundation or the BEKA websites

Powered by the fieldbus the BA484DF-F only requires a 2-wire connection, no additional power supply Zener barriers or galvanic isolators are required. The high contrast 86 x 45mm liquid crystal display incorporates a green backlight enabling the display to be read in all lighting conditions from full sunlight to total darkness.

Simple commissioning results from the use of standard display formats. Apart from loading the BA484DF-F configuration files onto the system host and selecting the fieldbus variables to be displayed, no programming is required. Configuration of the BA484DF-F Fieldbus Display is performed via the fieldbus and the instrument front panel push buttons.

ATEX, FM and IECEx intrinsic safety certification allows the BA484DF-F to be installed in gas and dust hazardous areas. The two fieldbus terminals comply with the Fieldbus Intrinsic Safety Concept (FISCO) simplifying system design and documentation, although connection to non-FISCO intrinsically safe systems is possible using the entity concept.

This allows a BA484DF-F display to be directly connected to almost any hazardous fieldbus segment, provided that the segment can supply the 25mA consumed by the display.

Six optional local alarm outputs may be linked to any of the displayed variables. Each isolated single pole solid state output may be conditioned as a combined high and low alarm, or as just a high or low alarm. All the outputs comply with the requirements for *simple apparatus* allowing them to switch any certified intrinsically safe load such as a sounder, lamp or solenoid valve. Alarm configuration and the alarm set point adjustment is performed via the BA484DF-F front panel push buttons, as the local alarms are not accessible from the fieldbus system host.

Comprehensive documentation includes a FOUNDATION™ fieldbus Interface Guide.

For panel mounting applications see the BA488CF-F datasheet. This instrument has a similar electrical specification but is housed in a 144 x 72 panel mounting enclosure.

BA484DF-F

FOUNDATION™ fieldbus Fieldbus Indicator 8 variables

*Intrinsically safe for use
in gas and dust
hazardous areas*

- ◆ FOUNDATION™ fieldbus protocol
- ◆ Compatible with most system hosts
- ◆ High contrast display with backlight
- ◆ Intrinsically safe
ATEX gas
or ATEX gas & dust
or FM & ATEX gas
All models have
IECEx certification
FISCO compliant
- ◆ Six optional local alarm outputs
- ◆ IP66 field mounting
GRP enclosure
- ◆ 3 year guarantee



BEKA associates

BEKA associates Ltd. Old Charlton Rd.
Hitchin, Hertfordshire, SG5 2DA, U.K.
Tel. (01462) 438301 Fax (01462) 453971
e-mail sales@beka.co.uk www.beka.co.uk

SPECIFICATION

Display					
Type	120 x 64 pixel liquid crystal				
Size	86.5mm x 45mm				
Backlight	Powered from fieldbus				
Screens	Standard format				
	1, 2, 3, 4 or 8 variables plus bargraph can include: units of measurement tag information				
Controls					
Front panel	Four push buttons scroll the indicator display between screens when the BA484DF-F is configured to display more variables than fit onto a single screen. Also used to configure optional local alarms.				
Fieldbus communication					
Voltage	9 to 32V (Limited by intrinsic safety parameters)				
Current	25mA				
Compliant with	IEC61158-2 Clauses 11 and 22 FOUNDATION™ fieldbus				
Protocol					
Function blocks					
FOUNDATION fieldbus™	1 x MAO (Multiple Analogue Output) <i>Selectable on-site</i>				
or	2 x IS (Input Selector)				
Intrinsic safety					
Europe ATEX					
Code	Group II Category 1G Ex ia IIC T5 Ga (Tamb = -40°C to +60°C)				
or	Group II Category 1D Ex ia IIIC T80°C Da (Tamb = -40°C to +60°C) IP66				
Cert. No.	ITS04ATEX22778 <i>Dust option, see How to order</i>				
Intrinsic safety parameters	<table border="0"> <tr> <td>U_i = 17.5V</td> <td rowspan="3">] FISCO compliant</td> </tr> <tr> <td>I_i = 380mA</td> </tr> <tr> <td>P_i = 5.32W</td> </tr> </table>	U _i = 17.5V] FISCO compliant	I _i = 380mA	P _i = 5.32W
U _i = 17.5V] FISCO compliant				
I _i = 380mA					
P _i = 5.32W					
Location	Gas Zone 0, 1 or 2: Dust Zone 20, 21 or 22				
USA FM					
Standard	<i>Option, see How to order</i>				
Code	3610 Entity CL I, II, III: Div 1: GP A, B, C, D, E, F & G T4 @ 60°C				
File	3022546				
Standard	3611 Nonincendive				
Code	CL I: Div 2: GP A, B, C & D, T4 @ 60°C CL II, III: Div 2: GP F & G, T4 @ 60°C				
File	3022546				
International IECEx					
Code	Group II Category 1G Ex ia IIC T5 Ga (Tamb = -40°C to +60°C)				
or	Group II Category 1D Ex ia IIIC T80°C Da (Tamb = -40°C to +60°C) IP66				
Cert. No.	IECEx ITS 05.0006 <i>Dust option, see How to order</i>				
Environmental					
Operating temp	-20 to 60°C (ATEX gas certification -40 to 60°C)				
Storage temp	-40 to 85°C				
Humidity	To 95% @ 40°C				
Enclosure	IP66				
EMC	In accordance with EU Directive 2004/108/EC BS EN 61326:1998				
Immunity	Operates normally with conducted 3Vrms interference between 0.15kHz and 80MHz, or radiated 10V/m interference between 80MHz and 1GHz. CISPR16-1/2 Class A				
Emissions					
Mechanical					
Terminals	Screw clamp for 0.5 to 1.5mm ² cable.				
Weight	1.6kg				
Accessories					
Alarms	Six galvanically isolated outputs which may be linked to displayed variables. Each alarm is configurable from instrument push buttons as: combined high and low alarm high or low alarm Note: Alarms are not accessible from the fieldbus system host				
Contacts	Isolated single pole solid state switch certified as simple apparatus. Ron less than 5Ω + 0.7V Roff greater than 1MΩ				
Intrinsic safety parameters	U _i = 28Vdc I _i = 200mA P _i = 0.84W				

DIMENSIONS (mm)

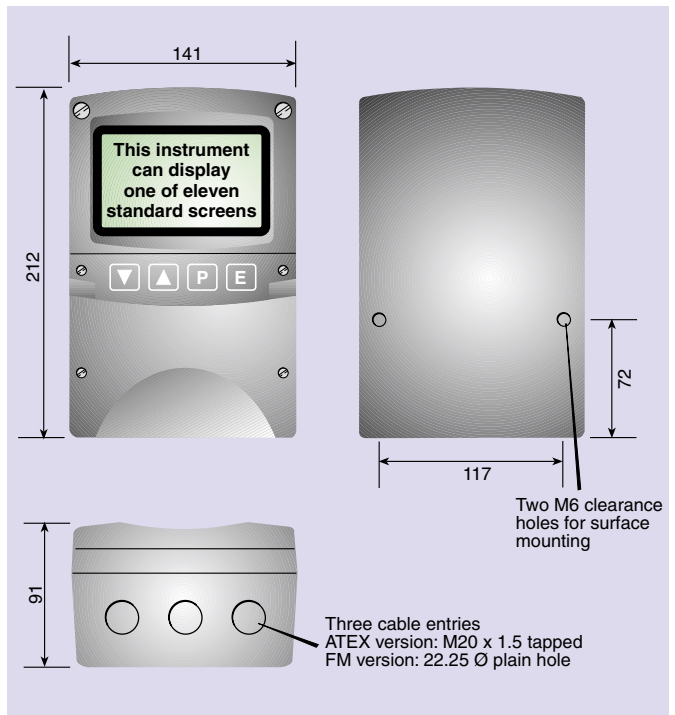

TERMINAL CONNECTIONS

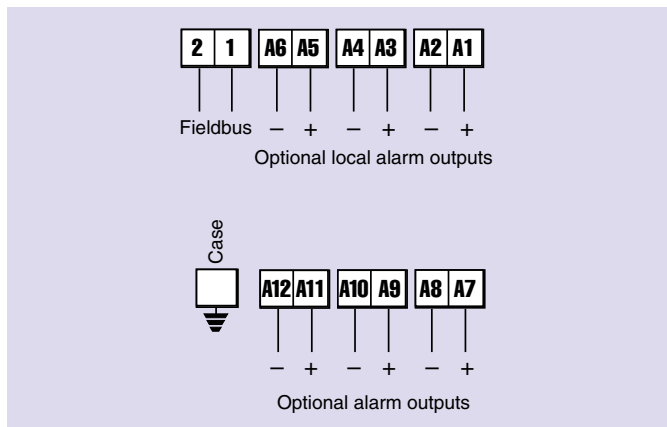

Tag strip	Printed legend behind the display window
Tag plate	Engraved stainless steel plate attached to the side of the instrument.
Pipe mounting kit	BA392D or BA393
FOUNDATION™ fieldbus interface guide	May be downloaded from www.beka.co.uk

HOW TO ORDER

Model number	Please specify BA484DF-F	
Certification	ATEX gas] All models have IECEx certification. Note: Cable entries differ for FM & ATEX models
or	ATEX gas & dust	
or	FM & ATEX gas	
Accessories	Please specify if required	
Six alarms	Alarms	
Tag strip	Tag strip legend	
Tag plate	Tag plate legend	
Pipe mounting kit	BA392D or BA393	

